

581271 (L-PHP15A) 15 W Horn Loudspeaker

- ✓ **Low-profile appearance**
- ✓ **Superior voice reproduction effect**
- ✓ **Water and dust proof , IP 66 compliant**
- ✓ **Easy for installation**
- ✓ **International safety standards compliant**
- ✓ **CE and RoHS compliant**

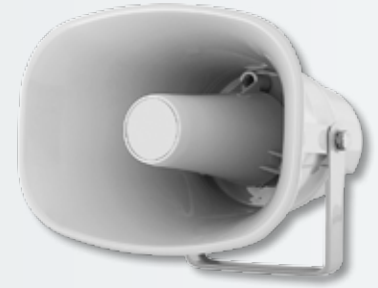

Overview

L-PHP15A is a 15 W horn loudspeaker. Its low-profile appearance and white cover makes it blend easily into many outdoor environments.

In addition to excellent voice reproduction and sound transmission effect, the loudspeaker is water and dust protected, making it ideal for noisy and spacious outdoor applications, such as sports fields, parks, exhibition halls, factories and train stations etc.

The horn loudspeaker is supplied with strong adjustable mounting bracket, enabling the operator to complete the installation at ease.

Mounting

The horn loudspeaker is supplied with sturdy adjustable mounting brackets, allowing the sound beam to be accurately directed.

Power setting

The horn loudspeaker includes a 100 V transformer with taps on the primary winding to allow different power settings. Nominal full-power, half-power can easily be selected by connecting the amplifier output to the appropriate tap.

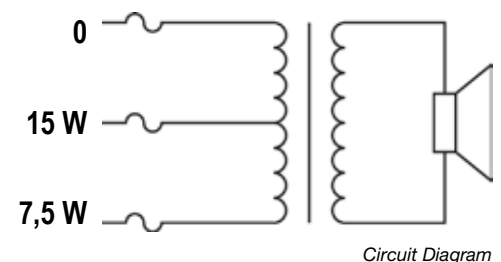
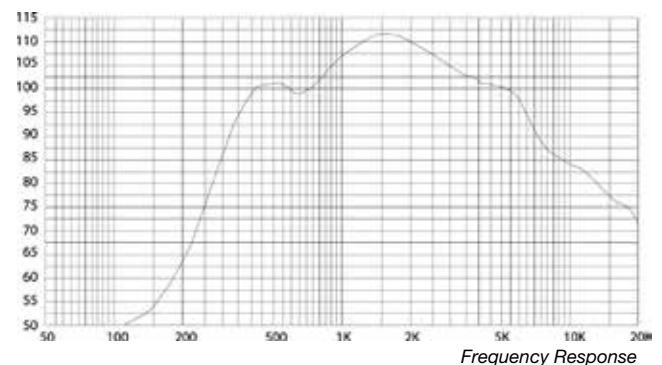

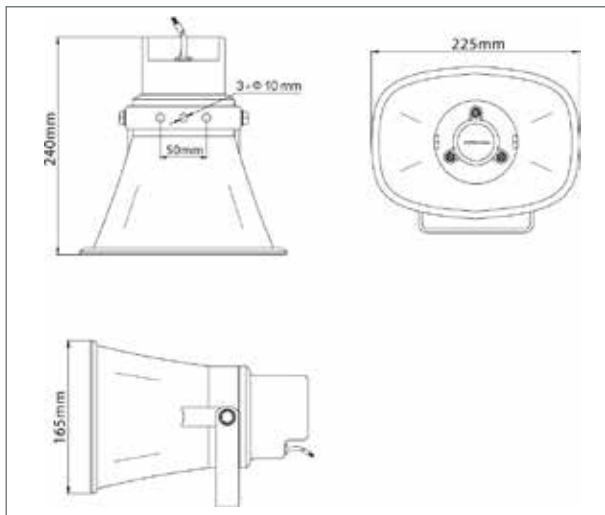

Dimensions

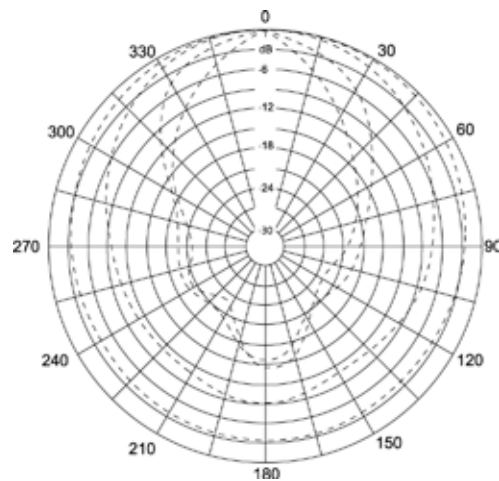

Polar Diagram

Specifications

Electrical

Max. power	25 W
Rated power	15 W
Power tapping	15 W / 7.5 W
SPL @ 15 W / 1 m (350 Hz ~ 7 kHz)	115 dB
SPL @ 1 W / 1 m (350 Hz ~ 7 kHz)	103 dB
Frequency range (- 10 dB)	350 Hz ~ 8 kHz
Dispersion angle (1 kHz / -6 dB)	140 °
Rated input voltage	100 V / 70 V
Rated impedance	667 Ω / 1.3 k Ω
Connection	Flexible wire

Mechanical

Dimensions	225 mm x 165 mm x 240 mm
Weight	1.56 kg
Color	White (RAL 9003)
Material	ABS
IP rating	IP 66

Environmental

Operating temperature	- 25 °C ... + 55 °C
Storage temperature	- 40 °C ... + 70 °C
Relative humidity	< 95 %

Order information

Part No.

Catalog description	15 W horn loudspeaker
Part number	581271
Type	L-PHP15A